

Do you like to use the devices more versatile instead of unilaterally? Universal distributor sockets support you in this.

- Vertical and horizontal use.
Connect workplaces of several levels over one another and next to one another. This directs your media in a direct path to the required delivery point.
- Safety via well thought out connection brackets.
The side connection is at a 90 ° angle. Mount your service units, consumers and pipes simply directly on the wall. Escape and transport routes remain clear.
- Flexible use.
The six connection options – 2 x front, 2 x side, 1 x above, 1 x below – offer the maximum flexibility of use.
- Available with or without couplings.



UVDS12-2



UVD12-6

Technical data:

Made of plastic PA6 GF 30

End and through distributor sockets made of high strength, glass fibre reinforced plastic (PA6 GF 30) with large range of applications. Optionally 1 or up to 3 connection options as well as 2 thread sizes for internal and external threads (cannot be combined). For vertical carrying of media.

Universal distributor socket with up to 6 connection options. Suitable for vertical and/or horizontal carrying of media or the secure connection (avoidance of existing components) of pressure reducer or maintenance device, for example.

All distributor sockets have a durable brass threaded insert, whose shape secures it against rotation and against axial shift due to its shape.

Suitable for media compressed air (ambient temperature -10 °C to 50 °C) or water (ambient temperature 1 °C to 50 °C). Drilling diagram dimensions are identical for all distributor sockets, so a simpler and more flexible exchange between end, through and universal distributor sockets is ensured.

Caution:

Note that the distributor sockets should not be installed in danger zones. Danger zones are, for example, transport routes, escape routes, etc.

Operating pressure	Max. 15 bar
Operating temperature in air	-10 °C to 50 °C
Operating temperature in air	1 °C to 50 °C
Housing	Glass fibre-reinforced plastic PA6 GF 30
Port	Brass
Max. tightening torque brass thread	12 Nm
Max. tightening torque mounting holes	4 Nm

Universal distributor with through-hole thread, PN 15

Art. No.	Type No.	Inlet thread	Through-hole thread	Thread
194135	UVD12-6	G 1/2	G 1/2	6 x G 1/2



UVD12-6

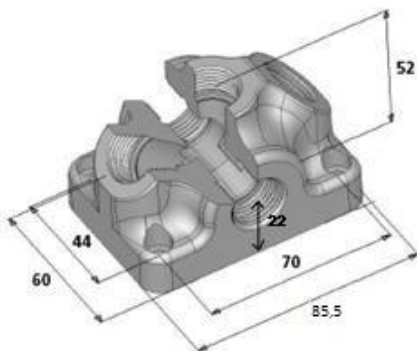

UVD12-6

Technical data:

Made of plastic PA6 GF 30

End and through distributor sockets made of high strength, glass fibre reinforced plastic (PA6 GF 30) with large range of applications. Optionally 1 or up to 3 connection options as well as 2 thread sizes for internal and external threads (cannot be combined). For vertical carrying of media.

Universal distributor socket with up to 6 connection options. Suitable for vertical and/or horizontal carrying of media or the secure connection (avoidance of existing components) of pressure reducer or maintenance device, for example.

All distributor sockets have a durable brass threaded insert, whose shape secures it against rotation and against axial shift due to its shape.

Suitable for media compressed air (ambient temperature -10 °C to 50 °C) or water (ambient temperature 1 °C to 50 °C). Drilling diagram dimensions are identical for all distributor sockets, so a simpler and more flexible exchange between end, through and universal distributor sockets is ensured.

Caution:

Note that the distributor sockets should not be installed in danger zones. Danger zones are, for example, transport routes, escape routes, etc

Operating pressure	Max. 12 bar
Operating temperature in air	-10 °C to 50 °C
Operating temperature in water	1 °C to 50 °C
Housing	Glass fibre-reinforced plastic PA6 GF 30
Port	Brass
Max. tightening torque brass thread	12 Nm
Max. tightening torque mounting hole	4 Nm



UVDS12-2

Universal junction socket, with 2 safety couplings I.D. 7.4

Art. No.	Type No.	Inlet thread	Coupling	Width mm	Height mm	Depth mm
205213	UVDS12-2	G 1/2	2 x safety coupling	86,0	60,0	115,0

Application examples:

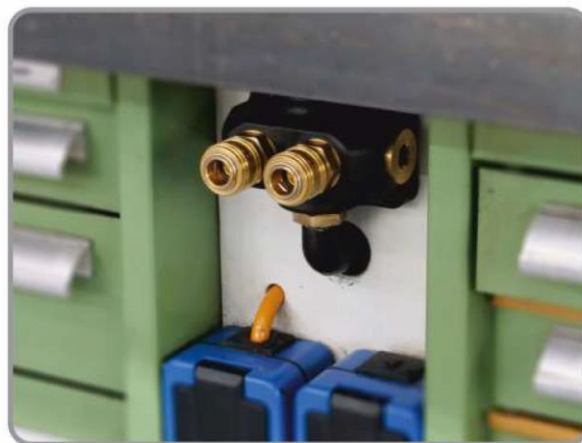
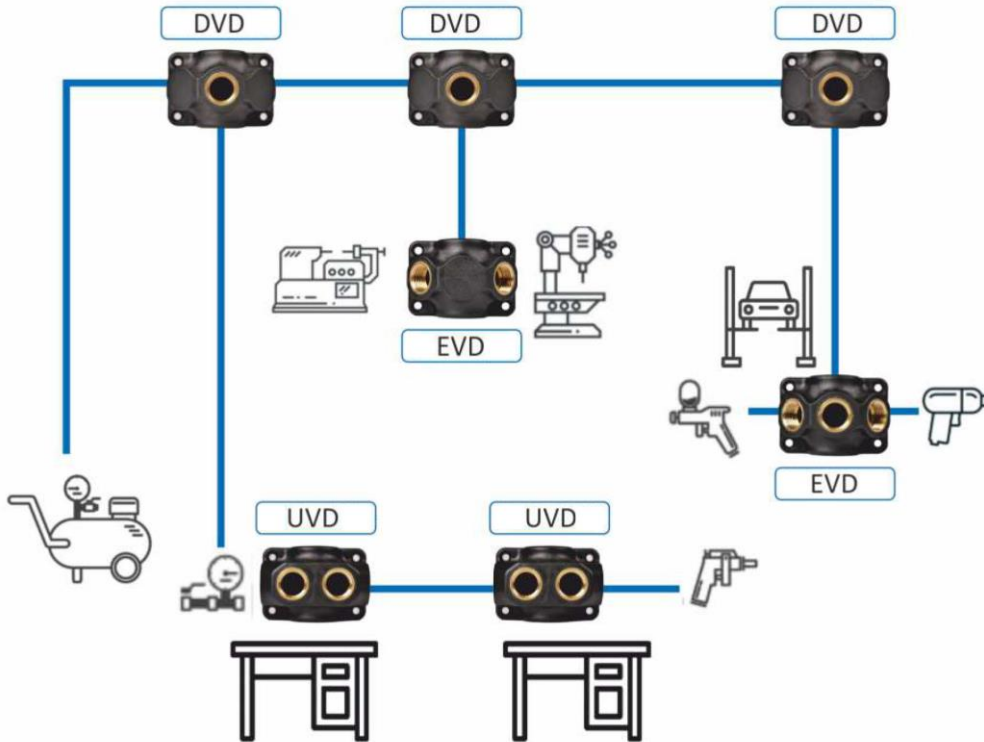

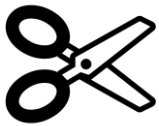

Drilling Template for cutting out:

Drillings in the box: \varnothing 5.5 mm
Ideal plugs: \varnothing 6 mm
Ideal screws: \varnothing 4 mm flat head

Installation location

The installation location of the quick-connect coupling must be selected so that the health of the person operating it cannot be harmed by sources of danger in the immediate surroundings, e.g. from slipping, jamming, contaminating or burning.

Low pressure applications

Threads for low-pressure applications are, if series-related no corresponding coatings or sealing rings are present, to be provided with suitable sealing materials, such as a PTFE belt or liquid sealing agent. Here the resistance to the flowing medium must be paid attention to.

Service manual

Quick-connect couplings are predominantly maintenance-free, if used in standard applications and handled carefully. The selection of the quick-connect coupling must be compatible with the intended purpose of use and material. Depending on the operating conditions it is recommended to provide the following points during maintenance:

External visual inspection with dirt in the functioning area of coupling and plug (seal area, control elements) these must be cleaned. The following distinguishing symptoms require replacement of the corresponding parts: Torn, damaged, heavily damaged or corroded parts, leaks on coupling and / or plug parts.

Function test under maximum Max. operating pressure can be used to test the quick-connect coupling for possible malfunctions and leaks. During the testing and operating phase it must be ensured that the operating personnel work protected.

Replacement intervals for quick-connect couplings must, if available, be adapted to the state or technical standards. However, also operating experiential values, which result from the required operational safety and the conditions of use, such as downtimes, coupling frequency, Max. operating pressure and properties of the medium, are critical for establishing the replacement intervals.

Pulsating tool

When using pulsating tools it is recommended to observe the standard ISO 6150, § 7.1. It recommends installing a minimum 300 mm long, flexible hose between the pulsating tool and the quick-connect coupling. The oscillating forces are taken by the hose piece and thus increase the service life of the quick-connect coupling. No warranty can be made for couplings mounted directly on pulsating tools.

Flow direction

The recommended flow direction is from the coupling to the plug if nothing else is specified in the technical data sheet.



Application with hoses

When using hoses the permissible Max. operating pressure and the working temperature must absolutely be observed and suitable hose connections must be seen to.